

# Installation

Ready to install your window?  
We'll take you through the  
process step-by-step.

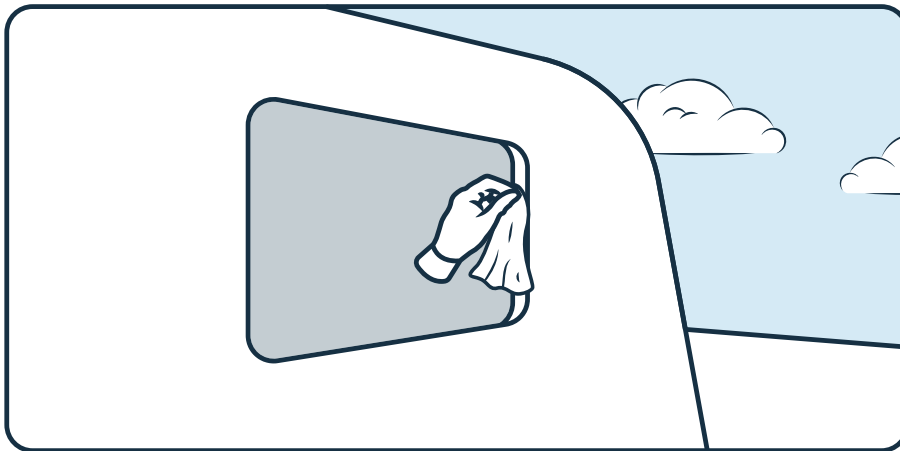

## Step 1

**Clean window opening  
on your vehicle.**

Clean dust and oil from  
around rough opening.

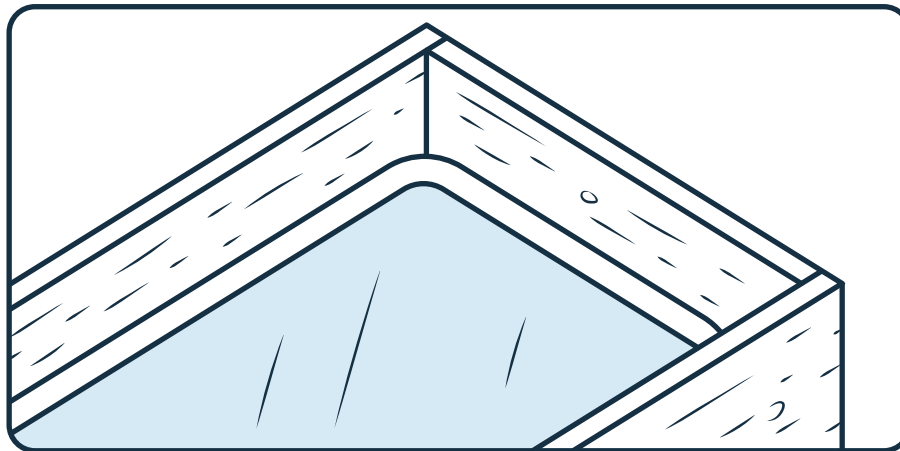

## Step 2

**Unpacking your window**

Remove window from crate  
and position on a clean,  
non-abrasive surface. Position  
clamp ring facing up.

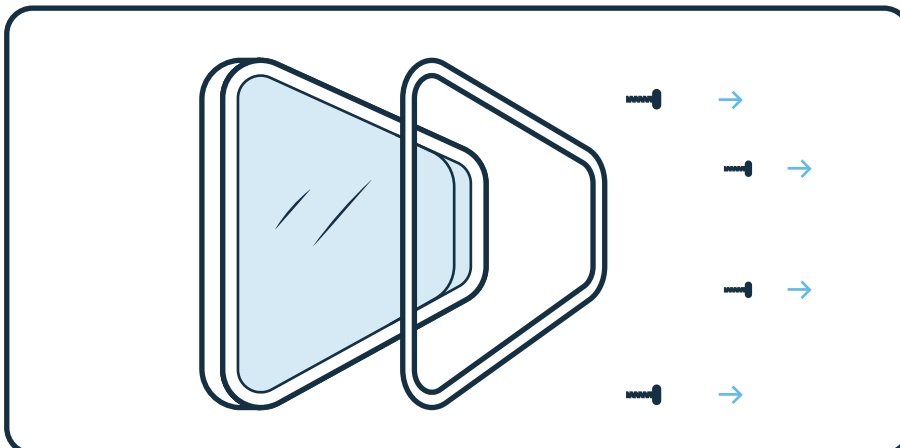

## Step 3

**Remove clamp ring screws**

Remove all clamp ring screws  
(making an index mark on 2 piece  
clamp rings will help insure  
correct replacement).

# Installation

Ready to install your window?  
We'll take you through the  
process step-by-step.

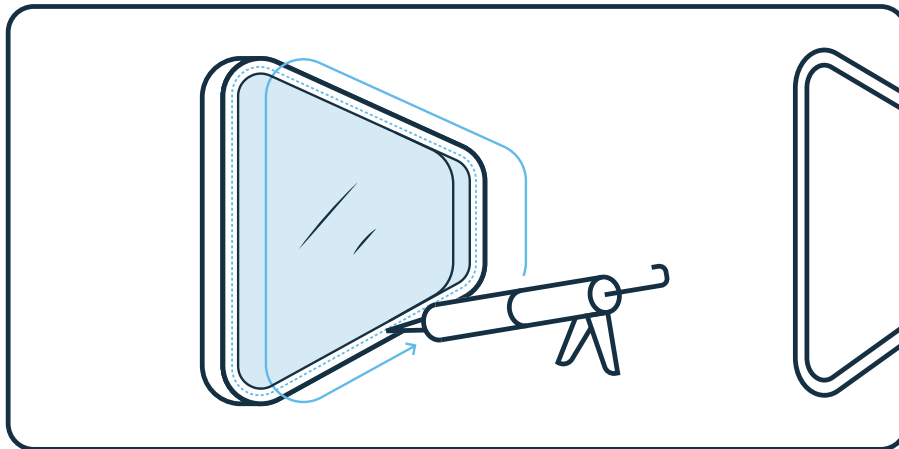

## Step 4

### Install bedding compound

First, wipe window flange with dry cloth to remove dust, then install bedding compound.

For bedding compound, use any of the following:

- Butyl rubber tape
- Double stick closed cell foam tape
- 100% silicone rubber sealant

(Do NOT use an adhesive)

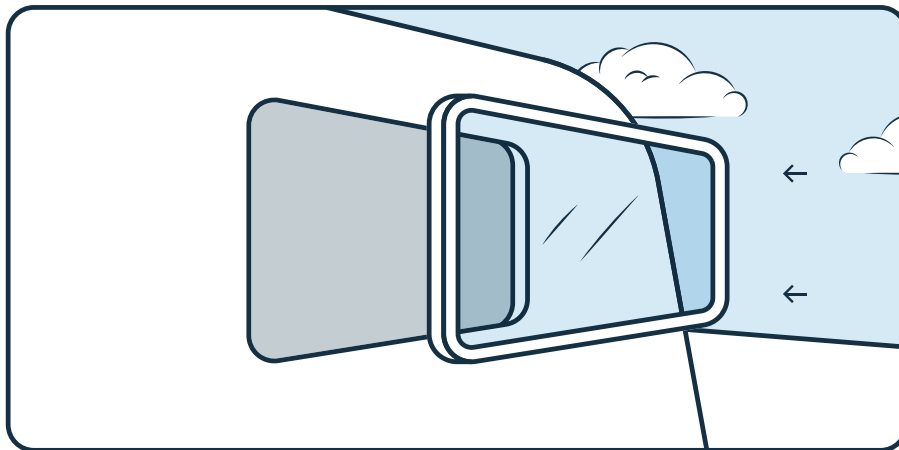

## Step 5

### Position your new window

Position window in rough opening from outside making sure of correct placement. All sliding windows must have drains toward bottom.

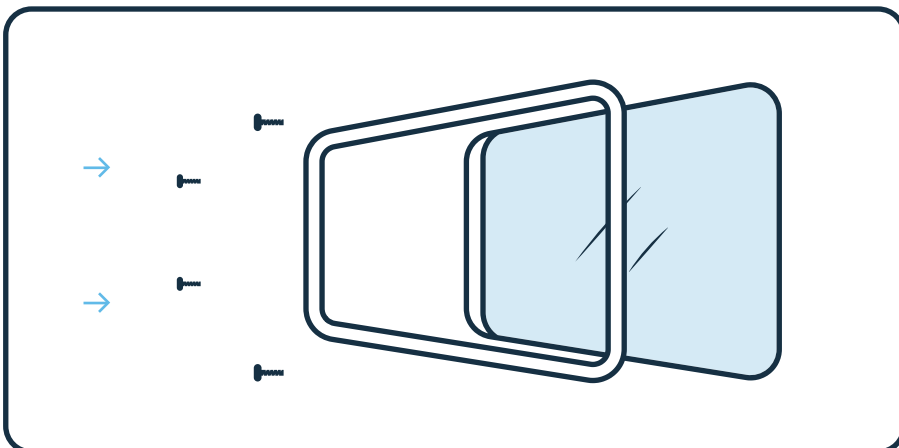

## Step 6

### Reinstall clamp ring

Reinstall clamp ring on inside, taking care to use existing screw holes.

Note: When using silicone bedding, do not fully tighten clamp ring until silicone is dry. Over tightening when wet WILL cause leaks.

# Installation

Ready to install your window?  
We'll take you through the  
process step-by-step.

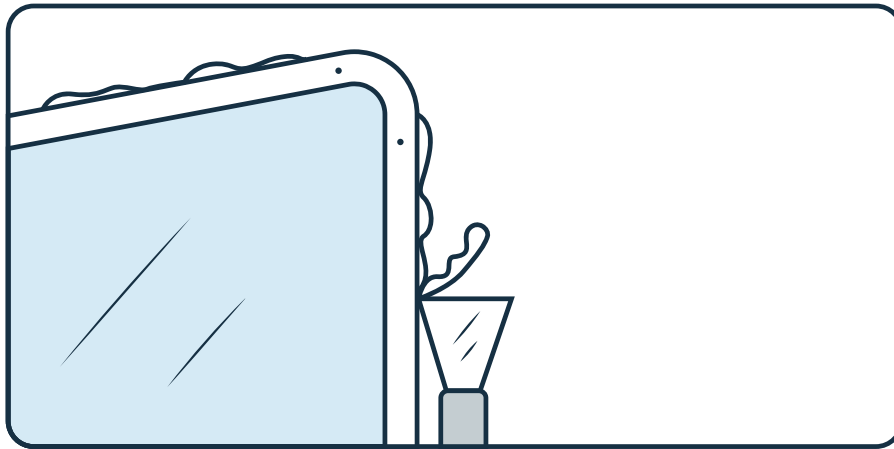

## Step 7

Clean off excess  
bedding material.

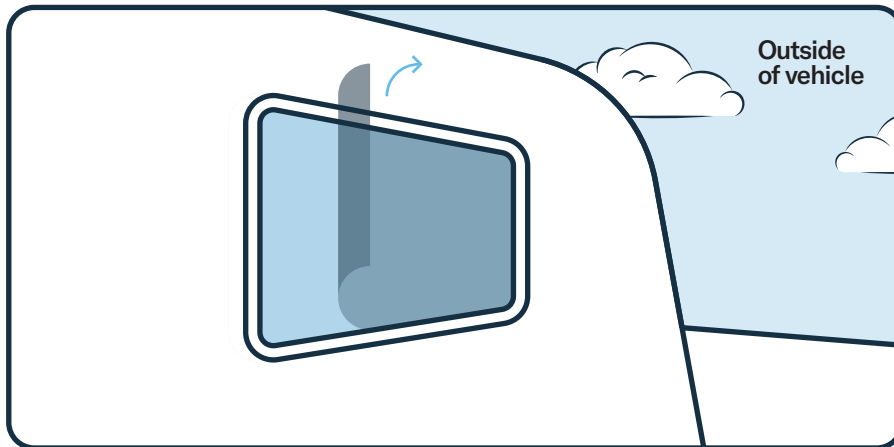

## Step 8

### Remove protective masking

For acrylic or polycarbonate  
glazing only, remove protective  
masking immediately after  
installation.

Delay or exposure to sunlight (UV  
rays) will make masking removal  
difficult.